

## Secondary air system

In petrol engine vehicles, secondary air injection is a proven method of reducing harmful substance emissions during cold starting. A petrol engine needs a "rich mixture" for reliable cold starting...

### Function



In petrol engine vehicles, secondary air injection is a proven method of reducing harmful substance emissions during cold starting. A petrol engine needs a "rich mixture" for reliable cold starting. This means that the fuel/air mixture contains excess fuel. As a result, high quantities of carbon monoxide and unburned hydrocarbons are produced during cold starting. Since the oxygen sensor emissions control and the catalytic converter have not yet reached their operating temperature at the time of this phase, these harmful exhaust gas components can escape into the environment if not re-treated.

To avoid this and reduce harmful substances during cold starting, ambient air containing high levels of oxygen ("secondary air") is injected into the exhaust gas manifold directly downstream of the exhaust valves using the secondary air system. This causes post-oxidation ("post-combustion") of the harmful substances, creating harmless carbon dioxide and water. The heat generated as a result of this process also heats the catalytic converter and reduces the time taken for the oxygen sensor emissions control to commence operation. The secondary air system comprises the secondary air pump and the secondary air valves.

### Structure of secondary air system

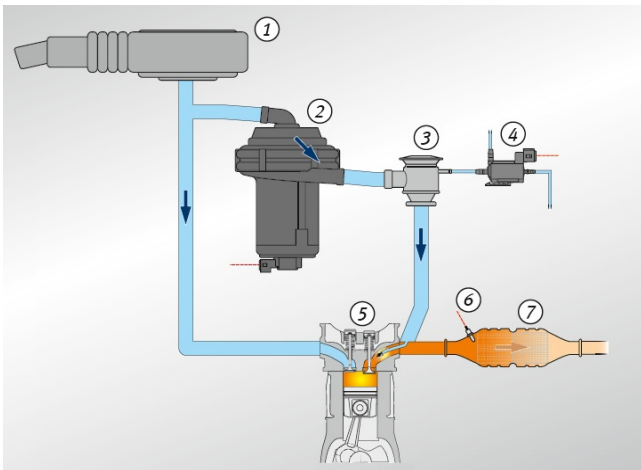

The secondary air pump

The secondary air pump must draw in ambient air and inject it into the exhaust gas manifold downstream of the exhaust valves. If the air is drawn not from the intake area but directly from the engine compartment, a separate air filter is built into the secondary air pump.

### Secondary air valve

- The secondary air non-return valve, for example, stops exhaust gas, condensation or pressure peaks in the exhaust tract (caused by misfiring, for example) causing damage to the secondary air pump.
- The secondary air shut-off valve, on the other hand, ensures that the secondary air is only supplied to the exhaust gas manifold during the cold start phase.

Secondary air valves are actuated in various ways – either by means of negative pressure controlled by an electric changeover valve or by opening due to the pressure generated by the secondary air pump. In later generation secondary air valves, the shut-off and non-return functions are combined in a "shut-off non-return valve". Electric secondary air valves are a very recent development. They have shorter opening and closing times than pneumatically controlled valves. Thanks to higher actuating forces, they are more resistant to sticking caused by soot or dirt. For monitoring by on-board diagnostics (OBD), electric secondary air valves can be fitted with a pressure sensor.

### Secondary air valve

The secondary air valves are installed between the secondary air pump and the exhaust gas manifold. They are available in various designs. The secondary air non-return valve, for example, stops exhaust gas, condensation or pressure peaks in the exhaust tract (caused by misfiring, for example) causing damage to the secondary air pump. The secondary air shut-off valve, on the other hand, ensures that the secondary air is only supplied to the exhaust gas manifold during the cold start phase.

Secondary air valves are actuated in various ways – either by means of negative pressure controlled by an electric changeover valve or by opening due to the pressure generated by the secondary air pump. In later generation secondary air valves, the shut-off and non-return functions are combined in a "shut-off non-return valve". Electric secondary air valves are a very recent development. They have

shorter opening and closing times than pneumatically controlled valves. Thanks to higher actuating forces, they are more resistant to sticking caused by soot or dirt. For monitoring by on-board diagnostics (OBD), electric secondary air valves can be fitted with a pressure sensor.

## Safety

Faults in the secondary air system often manifest themselves in the form of oscillating idling speed or a whistling noise during cold starting. They are signalled by the engine indicator lamp lighting up. The vehicle will often switch to emergency operation (reduced performance). Only a garage can rectify faults affecting a secondary air system.

## Environmental protection

Secondary air injection is the most important method of reducing the high concentrations of carbon monoxide and unburned hydrocarbons during cold starting. As such it makes an essential contribution to minimising harmful substance emissions in this phase and ensuring compliance with current emissions standards.

## Depreciation

The secondary air system is a maintenance-free vehicle system. However, exceeding maintenance intervals, extreme operating conditions, damage to mixture preparation or ignition and the use of poor-quality engine oils and fuels can lead to soiling and sticking of secondary air valves. A secondary air system that is in perfect working order is a prerequisite for passing the exhaust gas test carried out as part of the roadworthiness test.

## Bilder

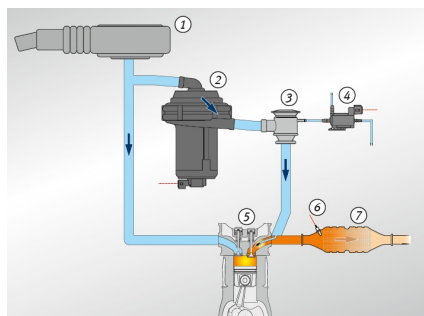
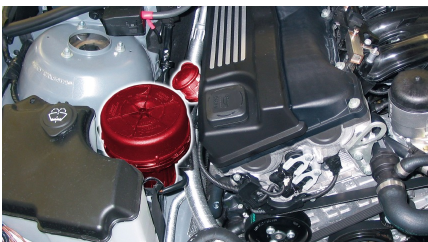

Diagram of a secondary air system



## Hersteller



MS Motorservice\_EN



Pierburg



Febi\_EN



Bosch

Quelle:

<http://www.my-cardictionary.comhttps://www.my-cardictionary.com/cardictionary/products/secondary-air-system.html>